

# Comparison Pumps

Case Version

Model

**PS 2500-G**

Pressure Ranges 0 ... 2500 bar (0 ... 35000 psi)

## Applications

Comparison pumps models PS 2500-G are suitable for testing and calibrating pressure gauges with ranges 0 - 2500 bar (35000 psi). Also other pressure instruments, e.g. pressure transmitters, can be tested.

The piston pump with star handle and the additional handpump are used for building up the pressure. Admission pressure by external pressure supply is recommended up to 10 bar (150 psi). Measuring medium is an acid free, thin oil.

The specimen gauge must be compared with a pressure gauge of higher accuracy (test gauge, please note our general information leaflet 2000).

Comparison pumps in case version suit even for permanent use, e.g. in test workshops. Furthermore, the instrument connection tubes are provided with filters to avoid contamination of the pump pipe system (see schematic drawing on reverse side, no. 5 and 6).

## Standard Configuration

**PS 2500-G** for pressure ranges 0 ...2500 bar (35000 psi)

### Instrument Connections

2 connections for measuring instruments (for the test gauge and for the specimen gauge), each connection provided with a union nut 1/2" BSP and a separate additional union nut M20x1,5

### Connection for External Pressure

Plug connection (Prestolock) for PA tubing N 4x1 and an adapter for tubing N 6x1

### Case

grey enameled cast aluminum 700 x 500 x 310 mm resp. 27.56" x 19.69" x 12.2" (length x depth x height)

### Piston and Cylinder

hardened alloy steel

### Spindle

alloy steel

### Measuring Medium

Acid free, thin oil

### External Admission Pressure

recommended, max. 10 bar (150 psi)

### Admission Pressure by Handpump

up to 1600 bar resp. 23000 psi  
(further up to 2500 bar / 35000 psi by using the piston pump)

### Weight

approx. 45 kg (99.21 lb)

### Inclosure to Shipment

- 1 instruction manual
- 1l special oil
- 2 special gaskets, each encasing an O-ring, for sealing the instrument connections (already installed)
- 4 O-rings as spare parts
- 2 union nuts M 20x 1,5  
(union nuts with 1/2" BSP are assembled)
- 2 adapter for N 6x1 flexible tubing  
(external admission pressure connection)

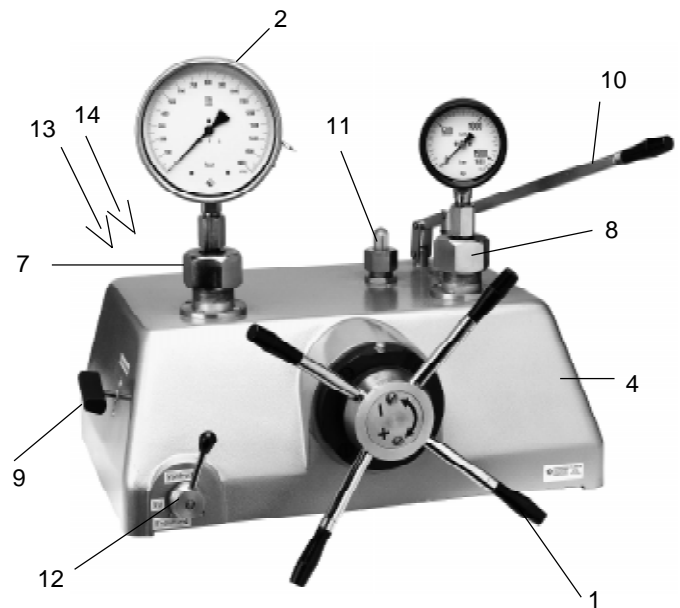

- 1 Piston pump with star handle
- 2 Test gauge (not part of standard supply)
- 4 Case
- 7 Connection test gauge ("Vergleichsgerät")
- 8 Connection specimen gauge ("Prüfling")
- 9 Pressure relief valve
- 10 Handpump
- 11 Reservoir for the measuring medium
- 12 Change-over valve for external admission pressure  
(Functions: – "Vordruck" = admission pressure  
– "Zu" = closed  
– "Entlüften" = vent)
- 13 "Eingang Vordruck" (= inlet of admission pressure)
- 14 "Entlüftung Vordruck" (= admission pressure venting)

Please also take note of the general informations about our comparison pumps on general information leaflet 10920.

## Optional Special Configurations

- PA tubing N 4x1 for Prestolock
- adapter fitting 4x1-tube connection X 1/4" NPT male
- liquid pump, with pneumatic drive, max. 1000 bar  
(instead of handpump)

## How to Order:

Please specify:

**Model Code:**            **PS 2500-G**    = 0 ...2500 bar

**Special Configurations:** (see above)

### Examples for Ordering Information:

- PS 2500-G
- PS 2500-G  
with adapter fitting 4x1 tube connection X 1/4" NPT



**ARMATURENBAU GmbH**

Manometerstraße ▪ D-46487 Wesel - Ginderich  
Phone: (0 28 03) 9130-0 ▪ Fax: (0 28 03) 10 35  
armaturenbau.com ▪ mail@armaturenbau.com



Subsidiary Company and Sales East Germany and Eastern Europe

**MANOTHERM Beierfeld GmbH**

Am Gewerbepark 9 ▪ D-08340 Beierfeld  
Phone: (0 37 74) 58 - 0 ▪ Fax: (0 37 74) 58 - 545  
manotherm.com ▪ manotherm@t-online.de

**10925**  
6/99

# User Instructions

The admission pressure can be connected to the comparison pump by a PA tubing N4x1, or, when using the adapter fitting, by a tubing N 6x1 (Prestolock).

An air control unit consisting out of pressure regulator and filter (pores  $\varnothing$  10-20  $\mu\text{m}$ , with oil and water separator) has to be placed into the connecting tube between admission pressure and comparison pump, for contamination protection of the comparison pump. (The filter is not part of standard supply.)  
The pressure regulator has to be limited to 10 bar (150 psi).

The use of external admission pressure (up to max. 10 bar resp. 150 psi) is recommended for a fast filling of the system and better handling of the handpump.

Before starting operation respectively before mounting the measuring instruments, close the valves [see schematic drawing, valves 9 and 12, switch lever (12) on position: "zu"].  
Make sure that the medium level of the reservoir (11) is sufficient (compare below).  
Turn the handwheel to the left to screw out the spindle with the piston completely all the way to the stop point.

Turn the handwheel just a little bit to the right to pump medium into the measuring instrument connections, up to the sealing borders.

Screw the measuring instruments now tight into the connections, the test gauge into connection (7) and the specimen gauge into connection (8). Take care of a proper sealing. Please use the delivered special gaskets (mounted ahead to the union nuts).

To fill up the complete measuring systems, switch the change-over valve (12) to "Vordruck" (= admission pressure) and use the external pressure up to 10 bar (150 psi). Produce the required pressure up to max. 1600 bar (23 000 psi) with the handpump (10), and higher pressure with the piston pump (1).

The exact pressure regulation now has to be done with the piston pump (1).

For decreasing the pressure open the pressure relief valve (9).  
To release the pressure down to 0 bar, change-over valve (12) has to be switched to "Entlüften" (vent), too.

Never open the measuring instruments connections when pressure is still inside of the system!

Please always pay attention to a clear locking-in of the lever of the change-over valve (12) at the exact position right above the tags.

## Refilling of the Medium Reservoir

The reservoir is supplied filled up and ready for use.  
Oil must be refilled immediately when the red float stick is no longer visible through the window of the oil column.  
Please use only the special oil included to shipment respectively re-ordered oil, which we will deliver upon request.

For refilling the reservoir, the change-over valve (12) has to be switched to "Entlüften". Now open the pressure-relief valve (9). Close the change-over valve (12) by turning the lever to the tag "Zu". Remove the union nut and the acrylic cap from the reservoir and fill in the oil up to the rim while pressing down the float. Close the reservoir.

## Maintenance

The maintenance is limited to periodical lubrication of instrument grease after approx. 50 working hours (lubricator nipples at the top side of the piston pump).

## Schematic Drawing

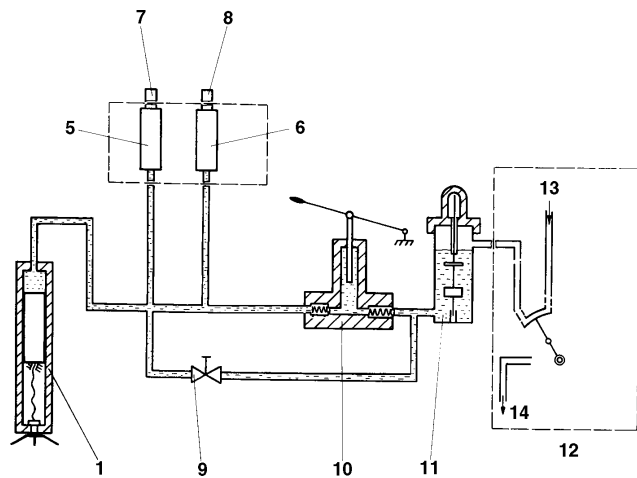

- 1 Piston pump with cylinder, piston, spindle and star handle
- 5 Filter
- 6 Filter
- 7 Connection test gauge ("Vergleichsgerät")
- 8 Connection specimen gauge ("Prüfling")
- 9 Pressure relief valve
- 10 Handpump
- 11 Reservoir for the measuring medium
- 12 Change-over valve for external admission pressure  
(Functions: – "Vordruck" = admission pressure,  
– "Zu" = closed,  
– "Entlüften" = vent)
- 13 Inlet of admission pressure (= "Eingang Vordruck")
- 14 Admission pressure venting (= "Entlüftung Vordruck")