

Diaphragm Pressure Gauges

with Horizontal Diaphragm

Case Sizes (NG) 100, 160, 250 (4", 6", 10")

Accuracy
±1.6 % F.S.

General
Information

Models
P..

An overview of our diaphragm pressure gauges with horizontal diaphragm, accuracy classes 1.6 and 2.5 according to EN 837-3, and technical information regarding all these models are to find in this leaflet. The specific data and ordering instructions for the different models are to find on the data sheets (see following pages).

Diaphragm pressure gauges with horizontal diaphragm can be used for measuring pressure (also vacuum or compound ranges) between 0/10 mbar and 0/25 bar (0/4" WC up to 0/400 psi).

The size of the measuring flange with the diaphragm depends on the pressure range:

Pressure Ranges	Flange-Diameter
0/10 to 0/250 mbar (0/4" to 0/100" WC)	160 mm (6")
0/.4 ¹⁾ to 0/25 bar (0/160"WC ¹⁾ to 0/400 psi)	100 mm (4")

Diaphragm pressure gauges are available in suitable versions for all kinds of media. For high viscosity, polymerization or heavy contamination problems versions with open flange connections (DIN or ANSI-flanges) and others are available.

Wetted parts can be made of alloy steel, 316 Ti, tantalum or other materials of high chemical resistance. A PTFE-lining of the lower flange and PTFE-foil for the diaphragm are further possibilities for protection of the wetted parts. Protection foils for the diaphragm such as PTFE, fine-silver, tantalum or others are only available for pressure ranges ≥ 40 mbar (resp. ≥ 16" WC or ≥ 6 psi). A protection foil lowers the accuracy class to ± 2.5 % f.s.

Liquid filled pressure gauges are used to protect the internals against damage caused by vibrations or pulsations, and/or to exclude ambient corrosives or condensations (outdoor services). Our standard filling fluid is glycerine, and it is a special oil when the pressure gauge is supplied with built-in electrical accessories. Filled gauges are available only for pressure ranges 0/160 mbar (0/60" WC) and above resp. model PChG ≥ 0/40 mbar, because the influence of the fluid column is significant.

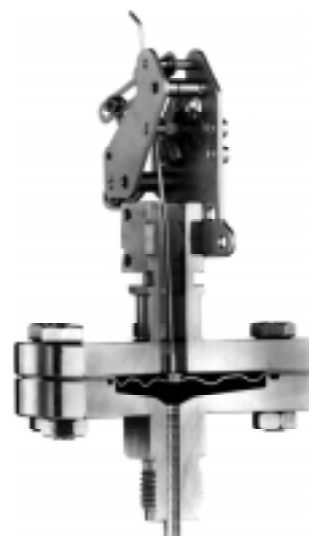

Characteristical Features

Accuracy According to EN 837-3

Accuracy class 1.6, i.e. ± 1.6 % of full span; accuracy class 2.5 (± 2.5 % of full span) for gauges with protection foil (PTFE, tantalum or others) and for liquid filled gauges with pressure ranges ≤ 250 mbar [measuring flange Ø 160 mm (6")].

Construction

The internals are basically the same for all models. Lower flange with thread or flange connection), diaphragm, upper flange with body, dial, movement and pointer constitute the complete pressure measuring device. The case itself with ring and lens just protects the pressure measuring device against influences from outside.

Diaphragm pressure gauges are not supplied with a pointer stop. For pressure ranges and scale divisions see table. The bar pressure ranges and subdivisions are according to EN 837-3. The standard dial shows a black scale on a white background.

A serial number is stamped on the dial for reference.

Pressure Limitations

Diaphragm pressure gauges can be used on normal service up to the full scale value and on pulsation service up to 90 % of full scale without loss of accuracy. All diaphragm gauges are overrange protected up to five times of full scale value, but max. up to 40 bar.

Temperature Limitations

Standard diaphragm gauges are temperature resistant up to +100 °C (+212 °F), but glycerine filled gauges max. up to +70 °C (150 °F). For services at higher temperatures please consult the factory. Minimum temperature limit for standard gauges: -20 °C (-4 °F); filled gauges for ambient temperatures below +10 °C (50 °F) have to be filled with a water/glycerine mixture or a silicone oil, please state temperatures below +10 °C (50 °F) when ordering!

Reference Temperature:

+20 °C (+68 °F)
The error caused by temperatures differering from +20 °C (+68 °F) is significant.

Electrical Accessories ³⁾

Limit switch contact assemblies (standard, magnetic, inductive or pneumatic) and potentiometric or capacitive transducers may be installed¹⁾, see data sheets 3190, 3291, 3390, 3690 and catalogue heading 9.

¹⁾ Pressure ranges 0/.4 bar resp. 0/400 mbar (0/160" WC) with built-in electrical accessories only available with measuring flange-Ø 160 mm (6").
²⁾ additional to EN 837-3

³⁾ not for PSK/PSKG

Pressure Ranges According to EN			Subdi- vision	Pressure Ranges	Sub- division
Positive	Compound	Negative			
mbar					
10	- 4 / + 6 - 6 / + 4	- 10 / 0	0,2	In Water vac. / psi	
16	- 6 / + 10 - 10 / + 6	- 16 / 0	0,5		
25	- 10 / + 15 - 15 / + 10	- 25 / 0	0,5	30" vac. .5" vac.	
40	- 15 / + 25 - 25 / + 15	- 40 / 0	1	Compound	
60	- 20 / + 40 - 40 / + 20	- 60 / 0	1		
100	- 40 / + 60 - 60 / + 40	- 100 / 0	2	30" / 15	1" / .5 psi
160	- 60 / + 100 - 100 / + 60	- 160 / 0	5	30" / 30	1" / .5 psi
250	- 100 / + 150 - 150 / + 100	- 250 / 0	5	30" / 60	2" / 2 psi
400	- 150 / + 250 - 250 / + 150	- 400 / 0	10	30" / 100	5" / 2 psi
				30" / 160	5" / 5 psi
				30" / 200	5" / 5 psi
				30" / 300	10" / 5 psi
bar					
0,4 ²⁾		- 0,4 / 0	0,01	Pressure (psi)	
0,6		- 0,6 / 0	0,01		
1,0		- 1 / 0	0,02	10	.1
		- 1200/0 mbar	20 mbar	15	.25
1,6	- 1 / + 0,6		0,05	30	.5
2,5	- 1 / + 1,5		0,05	60	1
4	- 1 / + 3		0,1	100	1
6	- 1 / + 5		0,1	160	2
10	- 1 / + 9		0,2	200	2
16	- 1 / + 15		0,5	300	5
25			0,5	400	5

Standard ranges and sub-
divisions 0/4"WC to 160"
WC upon request.



ARMATURENBAU GmbH

Manometerstraße • D-46487 Wesel - Ginderich
Phone: (0 28 03) 91 30-0 • Fax: (0 28 03) 10 35
armaturenbau.com • mail@armaturenbau.com



Subsidiary Company and Sales East Germany and Eastern Europe

MANOTHERM Beierfeld GmbH

Am Gewerbepark 9 • D-08340 Beierfeld
Phone: (0 37 74) 58 - 0 • Fax: (0 37 74) 58 - 545
manotherm.com • manotherm@t-online.de

3000

8/00

Selection of Models

DIAPHRAGM PRESSURE GAUGES Bezel Ring Case

Model **P**
Data Sheet 3100



Features

All applications where not a sealed case is required

- Case and bezel ring black
- Nominal case sizes (NG) 100, 160 and 250 mm (4", 6" and 10")

DIAPHRAGM PRESSURE GAUGES Case and Bayonet Ring Stainless Steel Standard (PCh) Glycerine Filled (PChG)

Models **PCh**
PChG
Data Sheet 3201



Features

Applications, especially where a sealed case (dirty damp or corrosive atmosphere) and / or chemical resistance is required

- Case and bayonet ring 304 stainless steel (1.4301)
- Laminated safety glass lens
- Blow-out relief on case back (Ø 1"); filled version with top blow-out assembly
- Nominal case sizes 100 and 160 mm (4" and 6")

DIAPHRAGM PRESSURE GAUGES Polyamide 6B Screw Ring Case Standard (PK) Glycerine Filled (PKG)

Models **PK**
PKG
Data Sheet 3300



Features

Applications as models PCh and PChG, especially for applications where a rugged, rust resistant, sealed case is required

- Black screw ring case glass fiber reinforced polyamide 6 B
- Laminated safety glass lens
- Blow-out relief on case back (Ø 1"); filled versions with top blow-out assembly
- Nominal case size 100 mm (4")

DIAPHRAGM PRESSURE GAUGES Polyamide 6B Screw Ring Case Solid Front and Blow-out Back Standard (PSK) Glycerine Filled (PSKG)

Models **PSK**
PSKG
Data Sheet 3400



Features

Applications as models PK, PKG, especially where additional safety features are desirable (protection of the viewer against projection of window parts in case of a failure). Liquid filled instruments are always preferable in safety version.

- **Safety Features: Solid front stainless steel between measuring system and dial, and a full blow-out safety back with retainer strap. When pressure is built up inside of the case, the entire case back separates allowing full relief.**
- Black screw ring case glass fiber reinforced polyamide 6B
- Solid front 304 stainless steel (1.4301)
- Full blow-out safety back polyamide 6 B
- Laminated safety glass lens 4 mm thick (marked SAFETY GLASS 4)
- Nominal case size 100 mm (4")

DIAPHRAGM PRESSURE GAUGES
Case and Bayonet Ring Stainless Steel
Solid Front and Blow-out Back
 Standard (PSCh)
 Glycerine Filled (PSChG)

Models **PSCh**
PSChG
 Data Sheet 3600

Features

Applications as models PCh/PChG, but especially where additional safety features are desirable (protection of the viewer against projection of window parts in case of a failure). Liquid filled instruments are always preferable in safety version.



- **Safety Features:**
Solid front stainless steel between measuring system and dial, and a full blow-out safety back. When pressure is built up inside of the case, the entire case back separates allowing full relief.
- Case and bayonet ring 304 stainless steel (1.4301), case with full blow-out safety back
- Solid front 304 stainless steel (1.4301)
- Laminated safety glass 4 mm (case size 100 mm / 4") respectively 6 mm (case size 160 mm / 6")
- Pressure equalizing membrane (4")
- Nominal case sizes 100 and 160 mm (4" and 6")

DIAPHRAGM PRESSURE GAUGES
with Limit-Switch Contact Assemblies
 Bezel Ring Case

Model **P**
 Data Sheet 3190



Case and Bayonet Ring Stainless Steel
 Standard (PCh)
 Oil Filled (PChOe)

Models **PCh**
PChOe
 Data Sheet 3291

Polyamide 6B Screw Ring Case
 Standard (PK)
 Oil Filled (PKOe)

Models **PK**
PKOe
 Data Sheet 3390

Case and Bayonet Ring Stainless Steel
Solid Front and Blow-out Back
 Standard (PSCh)
 Oil Filled (PSChOe)

Models **PSCh**
PSChOe
 Data Sheet 3690

DIAPHRAGM PRESSURE GAUGES
Bezel Ring Alloy Steel Black
Case and Flange Cast Iron

Model **Pm 160-2**

For Freight Wagons with
Pressure Discharge, DIN 6697

Data Sheet 3110



Features

- Bulk freight wagons with pressure discharge
- Special flange connection cast iron (DIN 6697)
 - Pressure range 0/4 bar
 - Red mark at 2.5 bar