

# Diaphragm Seals

Flange Type / Flange Type with Extension  
Sealing Face acc. to DIN or ASME, Flush Membrane

Models

MDM 7510, 7511, 7520

MDM 7515, 7521, 7525

## Applications

Diaphragm seals models MDM 75.. are used for aggressive, contaminated or hot media. Pressure gauges, pressure switches and pressure transmitters up to PN 400 (**6,000 psi**) for DIN flanges resp. 2,500 lb/sq.in. for ASME flanges can be attached.

## Construction

The membrane is flush welded to the body. The diaphragm seals are provided with a filling port in the upper part to simplify the filling of the complete measuring system after mounting and evacuation of the system. A special screw closes the filling port afterwards. This screw may not be opened.

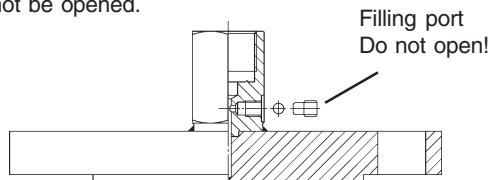

Further details about advantages and performances of chemical seals and important explanations about the required ordering information are on general information leaflet 7000, where you will also find an overview of other chemical seal models.

## Standard Configuration

**Instrument Connection:** G 1/2 (1/2" BSP) female

**Body:** 316 stainless steel (1.4571)

**Flange:** 316 stainless steel (1.4571)

## Membrane

316 stainless steel (1.4435), flush welded to the body, effective membrane  $\varnothing d_M$  depending on DN, see page 2 and 3

## Pressure Ranges

Pressure gauges: 0.6 bar resp. 1 bar to 400 bar, and 10 psi to 6,000 psi, also vacuum and compound ranges; minimum pressure ranges see tables page 2 and 3; data for pressure transmitters upon request

## Process Connection

MDM 7510 DIN flange connection DN 25, 50, 80, or 100, raised face DIN EN 1092-1 form B1, PN 16 or PN 40, form B2, PN 63 or PN100, raised face DIN 2526 form D, PN 160 ... PN 400

MDM 7511 DIN flange connection DN 15, 20, or 25, raised face DIN EN 1092-1 form B1, PN 40

MDM 7515 DIN flange connection DN 50, 80, or 100, raised face DIN EN 1092-1 form B1, PN 16 or PN 40, extension tube 50, 100, 150 or 200 mm (**1.97", 3.94", 5.91", 7.87"**)

MDM 7520 ASME flange connection DN 2", 3", or 4", raised face ASME B16.5, PN 150...2,500 lb/sq.in.

MDM 7521 ASME flange connection DN 1/2", 3/4" or 1", raised face ASME B16.5, PN 150 lb/sq.in.

MDM 7525 ASME flange connection DN 2", 3", or 4" raised face ASME B16.5, PN 150 or PN 300 lb/sq.in., extension tube 50, 100, 150, or 200 mm (**1.97", 3.94", 5.91", 7.87"**)

(See tables on the following pages for the details.)

**Filling Fluid:** Silicone oil

## Reference Temperature

+20 °C (+ 68 °F); dial inscription (pressure gauge): t<sub>A</sub> 20 °C



## Special Options

- **Flanges acc. to DIN 2526 upon request**
- **Instrument connection (female)** 1/4" BSP, 1/4"NPT or 1/2"NPT
- **Other sealing faces** upon request
- **Other flange sizes** upon request (not MDM 7511/7521)
- **Other extension tube length** (MDM 7515, 7525) upon request
- **Temperatures** (medium/ambient) differing from +20 °C (+68 °F)
- **Filling fluid** silicone oil PD5, fluorolube, paraffin oil, high-temperature oil, or vegetable oil; others upon request
- **Mating** calibrated for overrange protection
- **Tongue or groove** DIN 2512, or RJF groove, ASME B 16.5
- **Capillary line** between diaphragm seal and instrument  
(To consider: A mounting device for the measuring instrument is required, such as a rear flange or a front flange for pressure gauges, or a gauge holder bracket; The allowed length and configuration has to be suitable to pressure range and filling fluid; details upon request.)
- **Cooling element** (strongly recommended for medium temperatures +100 °C [+212 °F] and up, in case that the chemical seal shall be mounted to the gauge without capillary line)
- **Special material** (others, and for MDM 7511, 7521 upon request):  
MDM 7510 and 7520:  
**Membran** tantalum, hastelloy B2, C4, or C276, titanium, inconel 600, welded to the body, covering the complete sealing face (form B2);  
**Protection foil** PTFE or silver, covering the complete membrane and sealing face (form B2);  
**Coating** PFA, ECTFE for membrane and sealing face (due to the coating form B2);  
MDM 7515 and 7525:  
**Sheathing** tantalum for extension, membrane, sealing face (form B2)  
**Coating** PFA, ECTFE or for extension, membrane and sealing face (due to coating form B2);  
**Extension tube, membrane and sealing face** made from hastelloy B2, hastelloy C4, hastelloy C 276, or inconel 600;  
**Complete diaphragm seal** made from titanium

## How to Order:

Please note the detailed information about how to order on our general information leaflet 7000 and on the data sheet for the measuring instrument that shall be attached.

Model code: **MDM 7510, 7511, 7520, 7521  
7515, or 7525**

Process connection: compare tables following pages, e.g. **DN 50, PN 40 or ASME 3", 600 psi**

Extension tube length: for MDM 7515 / MDM 7525:  
**50, 100, 150, or 200 mm**  
(1.97", 3.94", 5.91", 7.87")

Special options: see above

Please state the process and ambient temperatures when differing from +20 °C (+68 °F), resp. when special cleaning conditions or other special conditions occur.



**ARMATURENBAU GmbH**

Manometerstraße 5 • D-46487 Wesel - Ginderich  
Phone: (0 28 03) 91 30 - 0 • Fax: (0 28 03) 10 35  
armaturenbau.com • mail@armaturenbau.com



Subsidiary Company and Sales East Germany and Eastern Europe

**MANOTHERM Beierfeld GmbH**

Am Gewerbepark 9 • D-08340 Beierfeld  
Phone: (0 37 74) 58 - 0 • Fax: (0 37 74) 58 - 545  
manotherm.com • mail@manotherm.com

**7500**

**5/03**

# Dimensions and Weights

<b>MDM 7510</b>	Flange acc. to	DIN EN 1092-1 Form B1	DN 25, 50, 80, 100	PN 16, PN 40	bar
	Flange acc. to	DIN EN 1092-1 Form B2	DN 25, 50, 80, 100	PN 63, PN 100	bar
	Flange acc. to	DIN 2526 Form D	DN 25, 50, 80, 100	PN 160 to PN 400	bar
<b>MDM 7511</b>	Flange similar to	DIN EN 1092-1 Form B1	DN 15, 20, 25	PN 40	bar

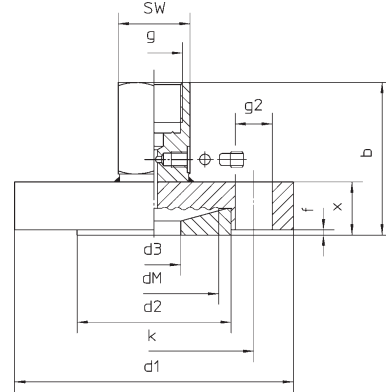
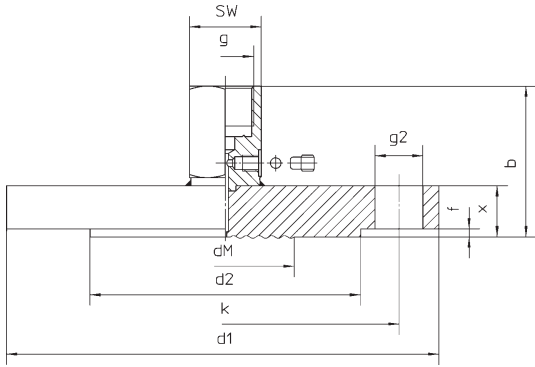

## Dimensional Data ( mm / inches ) and Weight ( kg / lb )

Model MDM	DN	PN bar/psi	b±2	d1	d2	d3	dM	f	g	g2	k	x	Minimum Pressure Ranges <sup>1)</sup>	SW	Weight (approx.)				
7511	15	40 600	62.5 2.46	95 3.74	45 1.77	15 .59	38 1.50	2 .08	G 1/2 1/2" BSP	4 x Ø 14 .55	65 2.56	25 .98	0 - 1.6 bar 30 psi	27 1.06	1.35 3.00				
	20		64.5 2.54	105 4.13	58 2.28	20 .79	52 2.05	2.5 .10			75 2.95	27 1.06	0 - 1 bar 15 psi		1.75 3.90				
	25		55.5 2.19	115 4.53	68 2.68	25 .98	59 2.32	3 .12			85 3.35	18 .71	0 - 6 bar 100 psi		2.05 4.50				
			57.5 2.26	165 6.5	102 4.02	52 2.05	3 .12	4 x Ø 18 .71			125 4.92	20 .79	0 - 1 bar 15 psi		3.00 6.60				
50	63 920	63.5 2.5	180 7.09	28 1.10				3.5 .14	4 x Ø 22 .87	135 5.31	26 1.02	4.60 10.10							
	100 1,450	65.5 2.58	195 7.68						4 x Ø 26 1.02	145 5.71	28 1.10	6.15 13.60							
	160 2,300	67.5 2.66	200 7.87						8 x Ø 26 1.02	150 5.91	30 1.18	7.70 17.00							
	250 3,600	75.5 2.97	210 8.27		8 x Ø 30 1.18	160 6.30	38 1.50		9.50 20.90										
7510	80	600	320 4,600	79.5 3.13	210 8.27	—	80 3.15	3 .12	4 .16	8 x Ø 26 1.02	160 6.30	42 1.65	2.05	0 - .6 bar 10 psi	14.70 32.40				
			400 6,000	89.5 3.52	235 9.25						8 x Ø 18 .71	160 6.30	20 .79		24 .95	4.35 9.60			
			16 230	57.5 2.26	200 7.87						8 x Ø 22 .87	170 6.69	28 1.10		6.95 15.30				
			40 600	61.5 2.42	215 8.46						8 x Ø 26 1.02	180 7.09	32 1.26		8.85 19.50				
	100	600	160 2,300	73.5 2.89	230 9.06	138 5.43	80 3.15	3 .12	4 .16	8 x Ø 26 1.02	180 7.09	36 1.42	10.05 22.20						
			250 3,600	83.5 3.29	255 10.04						8 x Ø 30 1.18	200 7.87	46 1.81	15.70 34.60					
			16 230	57.5 2.26	220 8.66						8 x Ø 18 .71	180 7.09	20 .79	4.75 10.50					
			40 600	61.5 2.42	235 9.25						8 x Ø 22 .87	190 7.48	24 .95	6.65 14.70					
			158 6.22	162 6.38	158 6.22						158 6.22	158 6.22	158 6.22	158 6.22	158 6.22	158 6.22	158 6.22	158 6.22	158 6.22
			158 6.22																

<sup>1)</sup> Related to pressure gauges 100 mm (4") and valid also for vacuum and compound range.

MDM 7520 Flange acc. to ASME B 16.5 2", 3", 4"  
MDM 7521 Flange acc. to ASME B 16.5 1/2", 3/4", 1"

PN 150 - 2,500 lb/sq. in.  
PN 150 lb/sq. in.

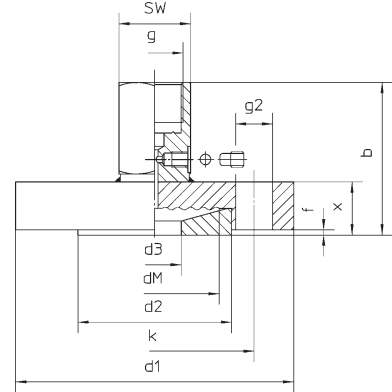
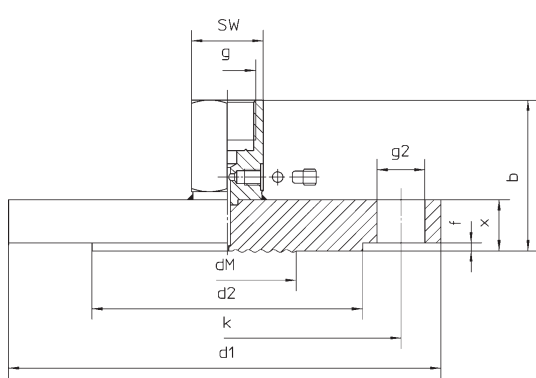

**Dimensional Data ( mm / inches ) and Weight ( kg / lb)**

Model MDM	DN	PN	b±2	d1	d2	d3	dM	f	g	g2	k	x	Minimum Pressure Ranges <sup>1)</sup>	SW	Weight (approx.)	
7521	1/2"	150	58.1 2.29	89 3.50	35.1 1.38	16 .63	26 1.02	1.6 0.06	G 1/2 1/2" BSP	4 x Ø 16 .63	60.5 2.38	20.6 .81	0 - 6 bar 100 psi	27 1.06	1.15 2.50	
	3/4"		60.1 2.37	99 3.90	42.9 1.69	20 .79	34 1.34				69.9 2.75	22.6 .89	0 - 2.5 bar 30 psi		1.25 2.80	
	1"		61.1 2.41	108 4.25	50.8 2	26 1.02	38 1.50				79.2 3.12	23.6 .93	0 - 1.6 bar 30 psi		1.75 3.90	
7520	2"	150	57 2.24	152 5.98	91.9 3.62	—	52 2.05	6.4 .25	G 1/2 1/2" BSP	4 x Ø 20 .79	120.7 4.75	19.5 0.77	0 - 1 bar 15 psi	27 1.06	2.60 5.70	
			300	60 2.36							165 6.50	127 5			22.5 .89	3.40 7.50
			600	69.5 2.74							216 8.50	163.1 6.42			44.5 1.75	4.30 9.50
			1,500	82 3.22							235 9.25	171.5 6.75			57.5 2.26	10.30 22.70
			2,500	95 3.74							235 9.25	171.5 6.75			57.5 2.26	15.80 34.80
	3"	150	61.5 2.42	191 7.52	127 5.00	—	80 3.15	6.4 .25	G 1/2 1/2" BSP	4 x Ø 20 .79	152.4 6	24 .95	0 - .6 bar 10 psi	27 1.06	5.10 11.20	
			300	66 2.60							210 8.27	168.1 6.62			28.5 1.12	7.00 15.40
			600	76 2.99							241 9.49	190.5 7.50			44.5 1.75	8.60 19.00
			900	82 3.23							267 10.51	203.2 8			54.5 2.15	13.30 29.30
			1,500	92 3.62							305 12.01	228.6 9			73 2.87	19.30 42.50
			2,500	110.5 4.35							305 12.01	228.6 9			73 2.87	35.00 77.20
	4"	150	61.5 2.42	229 9.02	157.2 6.19	—	80 3.15	6.4 .25	G 1/2 1/2" BSP	8 x Ø 20 .79	190.5 7.50	24 .94	0 - .6 bar 10 psi	27 1.06	7.20 15.90	
			300	69.5 2.74							254 10	200.2 7.88			32 1.26	11.70 25.80
			400	79 3.11							273 10.75	215.9 8.50			44.5 1.75	13.90 30.60
			600	82 3.23							292 11.50	234.9 9.25			51 2.01	17.50 38.60
900			88.5 3.48	292 11.50							234.9 9.25	51 2.01			27.10 59.70	

<sup>1)</sup> Related to pressure gauges 100 mm (4") and valid also for vacuum and compound range.

**MDM 7515** Flange acc. to DIN EN 1092-1 Form B1 DN 50, 80, 100 PN 16, PN 40 bar Extension tube  
**MDM 7521** Flange acc. to ASME B 16.5 2", 3", 4" PN 150, PN 300 lb/sq. in. Extension tube

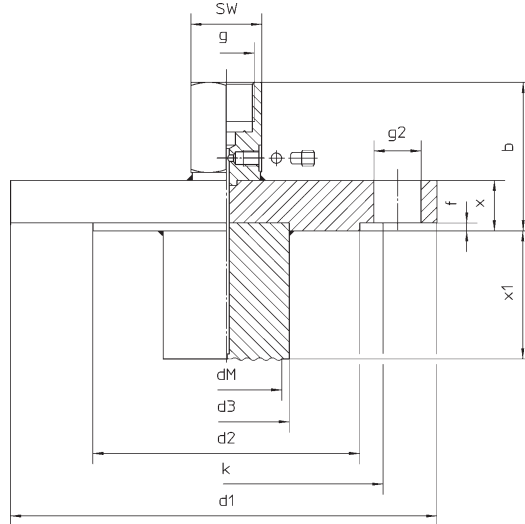

**Dimensional Data ( mm / inches ) and Weight ( kg / lb )**

Model MDM	DN	PN bar/psi	b±2	d1	d2	d3	dM	f	g	g2	k	x	x1	Minimum Pressure Ranges <sup>1)</sup>	SW	Weight (approx.)
7515	50	40 600	57.5 2.26	165 6.50	102 4.02	48.3 1.90	45 1.77	3 .12	G ½" BSP	4 x Ø 18 (.71)	125 4.92	20 .79	50 / 1.97	0 - 1 bar 15 psi	27 1.06	3.44 / 7.60
													100 / 3.94			3.76 / 8.30
		150 / 5.91	4.07 / 9.00													
		200 / 7.87	4.37 / 9.60													
	80	16 230	61.5 2.42	200 7.87	138 5.43	76 2.99	72 2.83	3.5 .14		8 x Ø 18 (.71)	160 6.30	24 0.94	50 / 1.97	0 - .6 bar 10 psi		5.25 / 11.60
													100 / 3.94			5.81 / 12.80
		150 / 5.91	6.37 / 14.00													
		200 / 7.87	6.92 / 15.30													
	100	16 230	57.5 2.26	220 8.66	158 6.22	94 3.70	90 3.54	4 .16		8 x Ø 22 (.87)	180 7.09	20 .79	50 / 1.97	0 - .6 bar 10 psi		6.15 / 13.60
													100 / 3.94			6.7 / 14.80
		150 / 5.91	7.27 / 16.00													
		200 / 7.87	7.82 / 17.20													
7525	2"	300	60 2.36	165 6.50	91.9 3.62	48.3 1.90	45 1.77	1.6 .06	8 x Ø 20 (.79)	127 5.00	22.5 .89	50 / 1.97	0 - 1 bar 15 psi	27 1.06	3.84 / 8.50	
												100 / 3.94			4.16 / 9.20	
		150 / 5.91	4.47 / 9.90													
		200 / 7.87	4.77 / 10.50													
	3"	150	61.5 2.42	191 7.52	127 5	76 2.99	72 2.83		8 x Ø 20 (.79)	152.4 6	24 .94	50 / 1.97	0 - .6 bar 10 psi		6.01 / 13.30	
												100 / 3.94			6.56 / 14.50	
		150 / 5.91	7.12 / 15.70													
		200 / 7.87	7.67 / 16.90													
	4"	300	66 2.60	210 8.27	157.2 6.19	94 3.70	80 3.15		8 x Ø 23 (.91)	168.1 6.62	28.5 1.12	50 / 1.97	0 - .6 bar 10 psi		7.90 / 17.40	
												100 / 3.94			8.46 / 18.70	
		150 / 5.91	9.02 / 19.90													
		200 / 7.87	9.57 / 21.10													
4"	150	61.5 2.42	229 9.01	157.2 6.19	94 3.70	80 3.15	8 x Ø 20 (.79)	190.5 7.5	24 .95	50 / 1.97	0 - .6 bar 10 psi	8.63 / 19.00				
										100 / 3.94		9.90 / 21.80				
	150 / 5.91	11.15 / 24.60														
	200 / 7.87	12.40 / 27.30														
4"	300	69.5 2.74	254 10	157.2 6.19	94 3.70	80 3.15	8 x Ø 23 (.91)	200.2 7.88	32 1.26	50 / 1.97	0 - .6 bar 10 psi	13.13 / 28.90				
										100 / 3.94		14.40 / 31.70				
	150 / 5.91	15.65 / 34.50														
	200 / 7.87	16.91 / 37.30														

<sup>1)</sup> Related to pressure gauges 100 mm (4") and valid also for vacuum and compound range.

The information in this leaflet is given in good faith, but we reserve the right to make changes without notice.