

Bimetal Thermometers

Bayonet ring case stainless steel case

Cl. 1 NCS 63
100
160

Model **TBiSch**
TBiGelCh

Application

Industrial temperature measurement, for fluid or gaseous media. The appropriate versions are suitable also for aggressive media as you find in chemical industries, petrochemistry, process technology, or apparatus engineering, and for food and beverage industries.

Nominal Case Sizes (NCS)

63, 100, 160 (2½", 4", 6")

Accuracy (DIN EN 13 190)

Class 1

Temperature Ranges (DIN EN 13 190)

See table page 3, temperature differences of 60 up to 500 K

Operating Temperature Limitations

Permanent: max. measuring range
Short time (approx. 1h): full scale value (max. nominal range)

Ambient Temperatures Limitations

-40 to +60 °C (-40 °F to +140 °F) (also for storage and transport)

Reference Temperature

+23 °C ±2 °C (73.4 °F ±3.6 °F)

Pressure Limitation

25 bar (350 psi) static pressure at the stem
(thermowell required for higher pressure!)

Protection Type (EN 60529 / IEC 529)

IP 65

Standard Configuration

Connection case / Stem

Typ TBiSch: rigid stem
Typ TBiGelCh: adjustable angle stainless steel

Case and Ring

304 stainless steel (1.4301), bayonet ring

Window

Single strength glass

Stem Position

Typ TBiSch: bottom, optionally center back (rm)
Typ TBiGelCh: back, with adjustable angle

Stem

Stainless steel 316 Ti (1.4571),
Ø 6 or 8 mm (.24 or .31"),
stem length up to 450 mm (17.72"),
stem type and minimum stem length see page 3

Measuring System

Bimetallic coil

Dial

Aluminum alloy, black figures, white background

Pointer

Adjustable pointer aluminum black

Adjustment

± 4 % at the pointer, after dismantling the bayonet ring

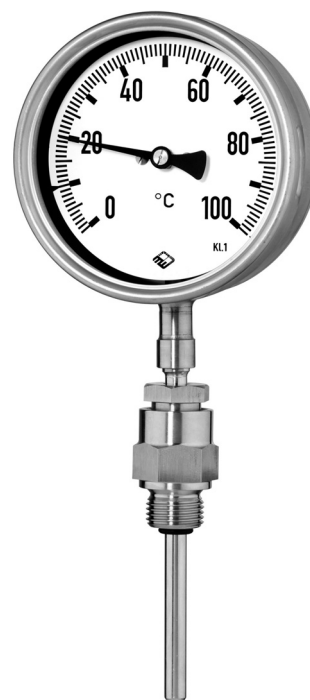

Special Configurations et. al.

- Stem type B 4.1 with neck tube (compare page 2) for version TBiSch...rm
- Other indication ranges or other units, e.g. °F or K, special scales such as dual ranges upon request
- Other connection threads resp. connection types upon request
- Other than vertical installation, top or side connection upon request
- Thermowell or flange thermowell acc. to DIN 43772, see data sheet 8310 (form 4, 4F), 8311 (form 5, 6, 7), 8312 (form 8, 9) and data sheet 8320 (with clamping ring connection); thermowell with fixing screw at the side upon request
- Acrylic glass window, or laminated safety glass upon request
- Red mark as movable plastic clip on the outside of the bayonet ring

Ordering Information:

Model: **TBiSch / TBiGelCh**
Nominal case size: **63, 100 or 160**
Ordering code for case configuration model TBiSch: Without: bottom stem position
rm: center back stem position
Nominal range: According to DIN resp. table page 3, e.g. 0-100 °C or -30/+ 50 °C
Stem configuration: Stem type **B1, B3, B4, B4.1, B5**
(compare page 3) Stem-Ø **6 mm or 8 mm**
Stem length **L**
Connection, e.g. G ½ B
Special options: See above
Accessory (if required): Thermowell according to DIN 43 772, data sheets 8310 ff

Example:

TBiSch 100, 0-100 °C, B4.1, Ø 8 mm, L =300 mm, G ½ B
TBiGelCh 160, 0-100 °C, B3, Ø 6 mm, L = 250 mm, G ½ B



ARMATURENBAU GmbH
Manometerstraße 5 D-46487 Wesel - Ginderich
Phone: (0 28 03) 9130-0 Fax: (0 28 03) 10 35
armaturenbau.com mail@armaturenbau.com



Subsidiary Company and Sales East Germany and Eastern Europe
MANOTHERM Beierfeld GmbH
Am Gewerbepark 9 • D-08344 Grünhain-Beierfeld
Phone: (0 37 74) 58-0 Fax: (0 37 74) 58-545
manotherm.com mail@manotherm.com

8101
11/07

Case Configuration, Code Letters, Dimensional Data and Weight

Model TBiSch

Rigid stem, bottom stem position, without code letter

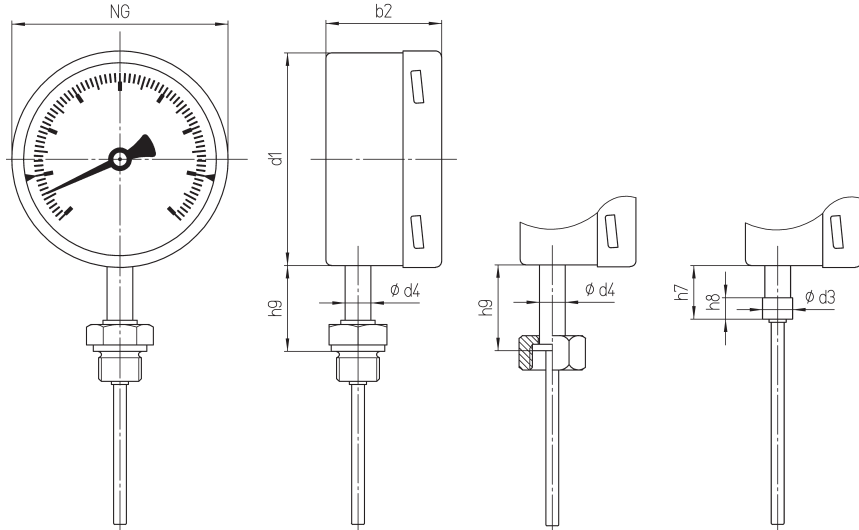

Stem type B4.1, rigid male connection

Stem type B3 / B4¹⁾ union nut / turnable male connection

Stem type B1, plain

Center back stem position, code letters **rm**

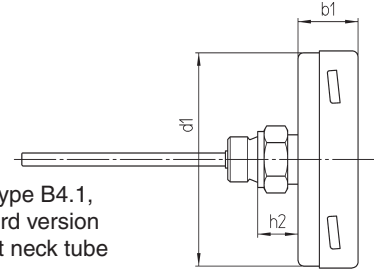

Stem type B4.1, standard version without neck tube

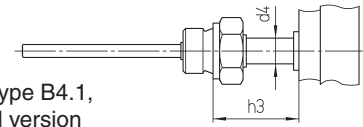

Stem type B4.1, special version with neck tube

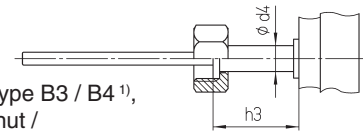

Stem type B3 / B4¹⁾, union nut / turnable male connection

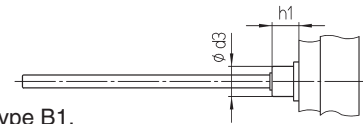

Stem type B1, plain

Model TBiGelCh

Adjustable angle stainless steel, stem adjustment up to 135° and case rotation up to 360°

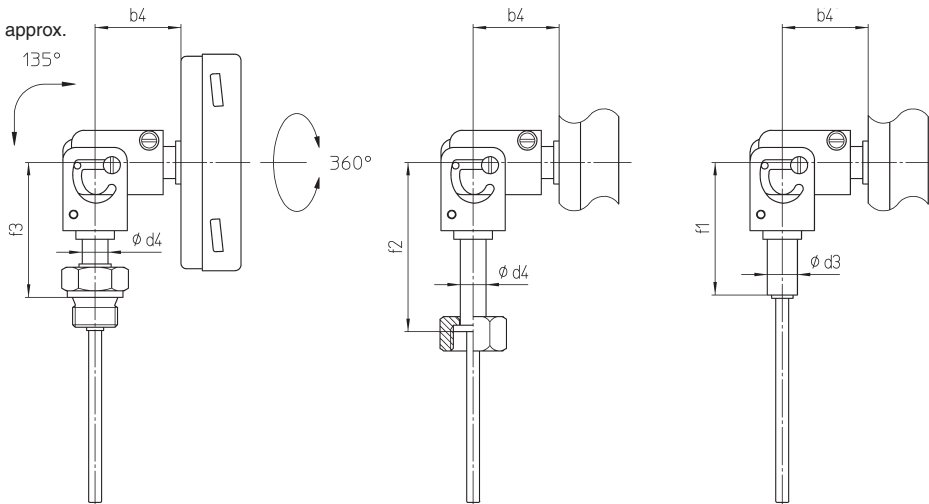

Stem type B4.1, rigid male connection

Stem type B3 / B4¹⁾ union nut / turnable male connection

Stem type B1, plain

Dimensions (mm / inches) and Weight (kg / lb)

NG (NCS)	b1	b2	b4	d1	d3	d4	f1	f2	f3	h 1	h2	h3 ³⁾	h7	h8	h9	Weight (approx.) ²⁾		
																bottom	TBiSch rm	TBiGelCh
63 (2½)	26 (1.02)	50 (1.97)		62 (2.44)												0.25 .55	0.20 .44	0.30 .66
100 (4)	28 (1.10)	54 (2.13)	40 (1.57)	98 (3.86)	14 (.55)	12 (.47)	62 (2.44)	79 (3.11)	63 (2.48)	12.5 (.49)	18.8 (.74)	40 (1.57)	25 (.98)	10.5 (.41)	40 (1.57)	0.40 .88	0.30 .66	0.40 .88
160 (6)	27 (1.06)	50 (1.97)		158 (6.22)												0.65 1.43	0.60 1.32	0.70 1.54

¹⁾ here shown: B3

²⁾ valid for stem type B1, Ø 6 mm, L = 150 mm, weight differs depending on stem type and length

³⁾ the max. stem length is reduced corresponding to dimension h3

Indication Ranges / Measuring Ranges, Limits of Error, Minimum Immersion Length Stem

Nominal Range °C	Measuring Range °C	Scale Subdivision °C	Max. Error °C	Minimum Immersion Length Stem ET _{min}	
				Ø 6 mm	Ø 8 mm
-20 / + 40	-10 / + 30	1	1	70	60
-20 / + 60	-10 / + 50	1	1	60	40
-30 / + 50	-20 / + 40	1	1	60	40
-40 / + 40	-30 / + 30	1	1	60	40
-40 / + 60	-20 / + 50	1	1	40	40
0 - 60	10 - 50	1	1	70	60
0 - 80	10 - 70	1	1	60	40
0 - 100	10 - 90	1	1	40	40
0 - 120	10 - 100	2	2	40	40
0 - 160	20 - 140	2	2	40	40
0 - 200	20 - 180	2	2	40	40
0 - 250	30 - 220	2	2,5	40	40
0 - 300	30 - 270	5	5	40	40
0 - 400	50 - 350	5	5	40	40
0 - 500	50 - 450	5	5	40	40

Values for °F upon request

Stem Types and Connection Types (Thermowells see data sheet 8310, 8311, 8312, 8320.)

Material: Stem and connection pieces made of stainless steel 316 Ti (1.4571)

Stem type B 1 (= form 1 DIN EN 13 190)
Plain stem (without thread connection)

Basis for stem type B5 (see below)

Stem diameter dF: 6 mm (.24") or 8 mm (.31")

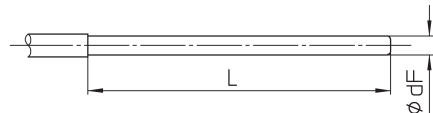

Minimum stem length $L_{min} = ET_{min}$

Stem type B 3 (= form 5 DIN EN 13 190)
Turnable union nut (see below, others upon request)

dF	G	SW	i
mm 6, 8 inches .24, .31	G ½	27	8.5
	½" BSP-f	1.06	.33
	G ¾	32	10
	¾" BSP-f	1.26	.39

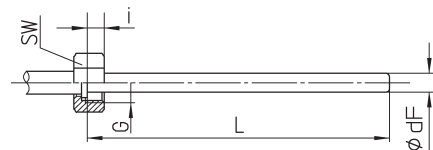

Minimum stem length $L_{min} = ET_{min} + i$

Stem type B 4 (= form 4 DIN EN 13 190)
Turnable male connection (see below, others upon request)

dF	G	SW	i
mm 6, 8 inches .24, .31	G ½ B	27	20
	½" BSP-m	1.06	.79



Minimum stem length $L_{min} = ET_{min}$

Stem type B 4.1 (= form 6 and form 7 DIN EN 13 190)
Rigid male connection thread (see below, others upon request)

dF	G	SW	d7	i
mm 6, 8 inches .24, .31	G ½ B	27	26	14
	½" BSP-m	1.06	1.02	.55
	G ¾ B	32	32	16
	¾" BSP-m	1.26	1.26	.63
	½" NPT	24	—	19
	¾" NPT	27	—	.75

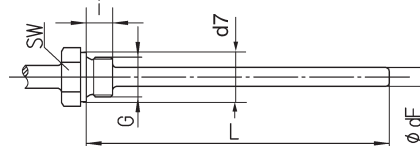

Minimum stem length $L_{min} = ET_{min} + i$

Stem type B 5 (= form 2 and form 3 DIN EN 13 190)
Stem type B 1 with Clamping ring connection including male thread, fitting adjustable on the stem

dF	G	SW	d ₇	i	L _κ
mm 6, 8 inches .24, .31	G ½ B	27	26	14	aprox. 37 1.46
	½" BSP-m	1.06	1.02	.55	
	G ¾ B	32	32	16	
	¾" BSP-m	1.26	1.26	.63	
	½" NPT	24	—	19	
	¾" NPT	27	—	.75	

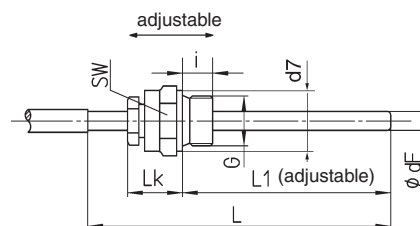

Minimum stem length $L_{min} = ET_{min} + 55 \text{ mm}$

The information in this leaflet is given in good faith, but we reserve the right to make changes without notice.